

Radio Controlled Clock Receiver

Description

The U4222B is a bipolar integrated straight through receiver circuit for the frequency of 40 kHz. The device is designed for radio controlled clock applications, in par-

ticular for the Japanese transmitter JG2AS.

Features

- Low power consumption
- Very high sensitivity
- High selectivity by quartz resonator
- Stop-function available
- Only a few external components necessary
- Digitized serial output signal

Block Diagram

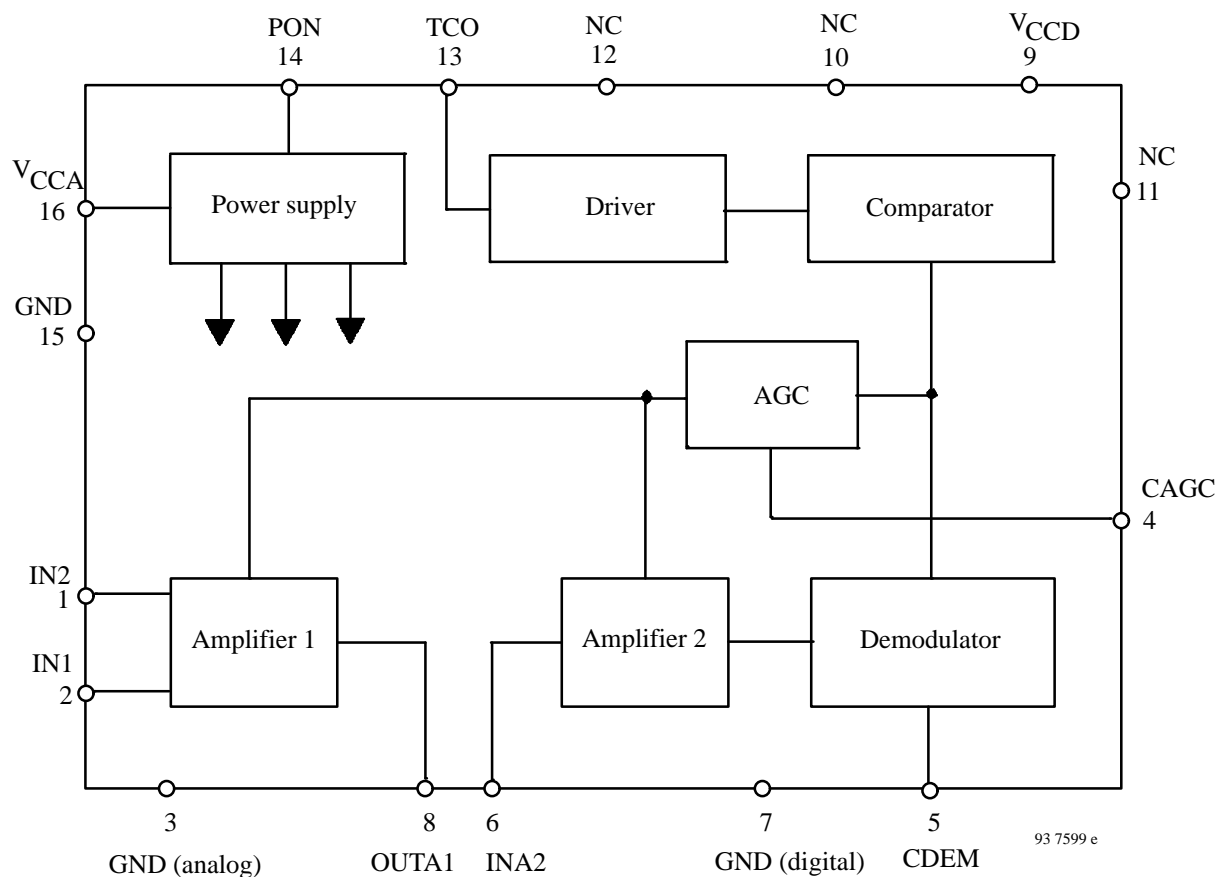
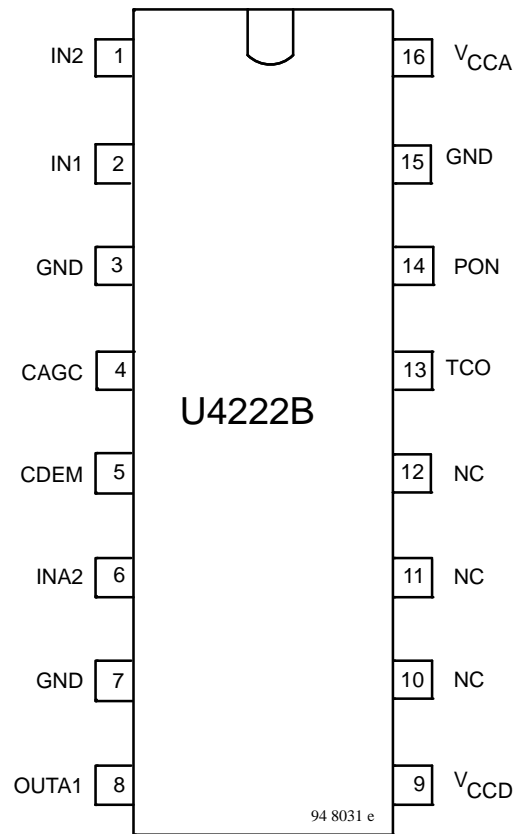

Figure 1.

Pin Description

Pin	Symbol	Function
1	IN2	Amplifier 1 – Input 2
2	IN1	Amplifier 1 – Input 1
3	GND	Analog ground
4	CAGC	Time constant of AGC
5	CDEM	Low pass filter
6	INA2	Amplifier 2 input
7	GND	Digital ground
8	OUTA1	Amplifier 1 output
9	V _{CCD}	Supply voltage (digital)
10	NC	Not connected
11	NC	Not connected
12	NC	Not connected
13	TCO	Time code output
14	PON	Power ON/OFF control
15	GND	Ground (substrate)
16	V _{CCA}	Supply voltage (analog)



IN1, IN2

IN2 is connected to pin 16 (V_{CCA}). A ferrite antenna is connected between IN1 and IN2. Q of antenna circuit should be as high as possible, but the temperature influence must be compensated. The resonant resistance should be 200 kΩ to 300 kΩ for optimal sensitivity.

OUTA1, INA2

To achieve a high selectivity, a quartz resonator is connected between the pins OUTA1 and INA2. It is used with the serial resonance frequency of the time code transmitter (e.g. 40 kHz JG2AS). The parasitic parallel capacitance C₀ of the quartz resonator should be 0.5 pF to 1 pF.

CAGC

A control voltage derived from the field strength is generated to control the amplifiers. The time constant of this automatic gain control (AGC) is influenced by the capacitor CAGC.

CDEM

After demodulation the signal is low pass filtered by the capacitor CDEM.

PON

If PON is connected to V_{CCD}, the U4222B receiver IC will be activated. The set-up time is typical 2.5 s after applying V_{CCD} at this pin. If PON is connected to GND, the receiver will go into stop mode.

TCO

The digitized serial signal of the time code transmitter can be directly decoded by a microcomputer. Details about the time code format of several transmitters are described separately. The output consists of a PNP current source and a NPN switching transistor T_S . The guaranteed source output current is $0.2 \mu\text{A}$ ($\text{TCO} = \text{high}$) and the sink current is $1 \mu\text{A}$ ($\text{TCO} = \text{low}$). Considering these output currents, the supply voltage and the switching levels of the following μC , the lowest load resistance is defined. The maximum load capacitance is 100 pF .

In order to improve the driving capability an external pull-up resistor can be used. The value of the resistor should be $4.7 \text{ M}\Omega$. To prevent an undefined output voltage in the power-down state of the U4222B, the use of this pull-up resistor is recommended.

An additional improvement of the driving capability may be achieved by using a CMOS driver circuit or a NPN transistor with pull-up resistor connected to the collector (see figure 2.). Using a CMOS driver this circuit must be connected to V_{CCD} .

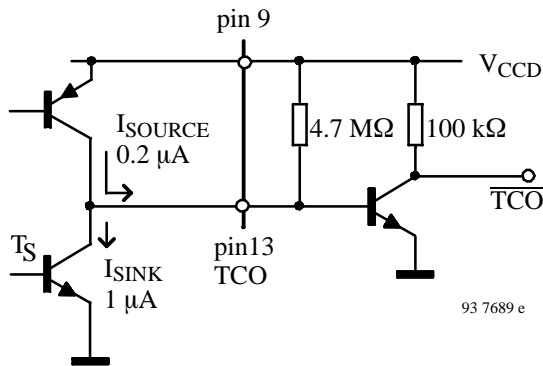

Figure 2.

Functional Description

The following description gives you some additional information and hints in order to facilitate your design, in particular the problems of the antenna.

Figure 3. shows the principal function of the receiver (simplified consideration).

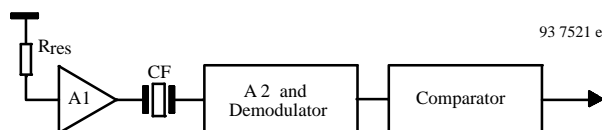

Figure 3.

R_{res} : resonant resistance, A1: preamplifier, A2: amplifier 2, CF: crystal filter

Condition for signal reception:
 $S/N \approx 4$ at comparator input.

Important parameters are:

$$V_{\text{NA}} = (4 k T R_{\text{res}})^{1/2}$$

$$BW_{\text{A}} = f_{\text{res}}/Q_{\text{A}}$$

input noise voltage density of preamplifier:

$$V_{\text{NA1}}: 40 \text{ nV/Hz}^{1/2} \text{ (typ)}$$

bandwidth of preamplifier:

$$BW_{\text{A1}}: 60 \text{ kHz (typ)}$$

bandwidth of crystal filter:

$$BW_{\text{CF}}: 16 \text{ Hz (typ)}$$

ultimate attenuation of crystal filter:

$$D_{\text{CF}}: -35 \text{ dB (typ)}$$

whereas:

- V_{NA} antenna noise voltage density
- k $1.38 \cdot 10^{-23} \text{ Ws/K}$ (Boltzmann constant)
- T absolute temperature
- BW_{A} bandwidth of antenna
- f_{res} resonant frequency
- Q_{A} Q antenna

The equivalent input noise voltage at the preamplifier input is:

$$V_{\text{N}} = \sqrt{\left(V_{\text{NA}} \cdot \sqrt{BW_{\text{CF}}} \right)^2 + \left(\frac{V_{\text{NA}} \cdot \sqrt{BW_{\text{A}}}}{D_{\text{CF}}} \right)^2 + \dots}$$

$$\dots + \left(V_{\text{NA1}} \cdot \sqrt{BW_{\text{CF}}} \right)^2 + \left(\frac{V_{\text{NA1}} \cdot \sqrt{BW_{\text{A1}}}}{D_{\text{CF}}} \right)^2$$

whereas:

$$R_{\text{res}} = 300 \text{ k}\Omega, BW_{\text{A}} = 1 \text{ kHz then } V_{\text{N}} \approx 0.4 \mu\text{V}$$

The condition for signal reception is:

$$S/N \approx 4 \Rightarrow \text{sensitivity} \approx 1.6 \mu\text{V}$$

That means that the noise voltage of antenna within the bandwidth of the crystal filter dominates and the bandwidth of antenna is uncritical for the sensitivity aspect.

U4222B

There is some consideration concerning the calculation of R_{res} :

in order to achieve high signal voltage:

R_{res} should be high

in order to achieve low antenna noise voltage:

R_{res} should be low

$R_{res} < 200 \text{ k}\Omega$:

the input noise voltage of A 1 dominates

$R_{res} > 300 \text{ k}\Omega$:

the antenna noise voltage dominates

That means the resonant resistance should be between 200 k Ω and 300 k Ω .

Q of antenna must be high for attenuation of interfering signals. But the temperature must not influence the resonance frequency.

Design Hints for the Ferrite Antenna

The bar antenna is the most critical device of the complete clock receiver. But by observing some basic rf design knowledge, no problem should arise with this part. The IC requires a resonance resistance of 200 k Ω to 300 k Ω . This can be achieved by a variation of the L/C-relation in the antenna circuit. But it is not easy to measure such high resistances in the RF region. It is much more convenient to distinguish the bandwidth of the antenna circuit and afterwards to calculate the resonance resistance.

Thus the first step in designing the antenna circuit is to measure the bandwidth. Figure 4. shows an example for the test circuit. The RF signal is coupled into the bar antenna by inductive means, e.g. a wire loop. It can be measured by a simple oscilloscope using the 10:1 probe. The input capacitance of the probe, typically about 10 pF, should be taken into consideration. By varying the frequency of the signal generator, the resonance frequency can be determined.

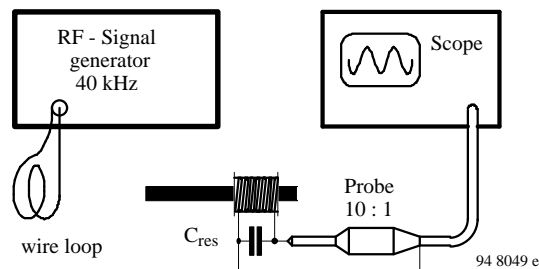

Figure 4.

Afterwards, the two frequencies where the voltage of the RF signal at the probe drops 3 dB down can be measured. The difference between these two frequencies is called

the bandwidth BW_A of the antenna circuit. As the value of the capacitor C_{res} in the antenna circuit is well known, it is easy to compute the resonance resistance according to the following formula:

$$R_{res} = \frac{1}{2 \cdot \pi \cdot BW_A \cdot C_{res}}$$

whereas

R_{res} is the resonance resistance,

BW_A is the measured bandwidth (in Hz)

C_{res} is the value of the capacitor in the antenna circuit (in Farad)

If high inductance values and low capacitor values are used, the additional parasitic capacitances of the coil must be considered. It may reach up to about 20 pF. The Q-value of the capacitor should be no problem if a high Q-type is used. The Q-value of the coil is more or less distinguished by the simple DC-resistance of the wire. Skin effects can be observed but do not dominate.

Therefore it should be no problem to achieve the recommended values of resonance resistance. The use of thicker wire increases Q and accordingly reduces bandwidth. This is advantageous in order to improve reception in noisy areas. On the other hand, temperature compensation of the resonance frequency might become a problem if the bandwidth of the antenna circuit is low compared to the temperature variation of the resonance frequency. Of course, Q can also be reduced by a parallel resistor.

Temperature compensation of the resonance frequency is a must if the clock is used at different temperatures. Please ask your dealer of bar antenna material and of capacitors for specified values of temperature coefficient.

Furthermore some critical parasitics have to be considered. These are shortened loops (e.g. in the ground line of the PCB board) close to the antenna and undesired loops in the antenna circuit. Shortened loops decrease Q of the circuit. They have the same effect like conducting plates close to the antenna. To avoid undesired loops in the antenna circuit it is recommended to mount the capacitor C_{res} as close as possible to the antenna coil or to use a twisted wire for the antenna coil connection. This twisted line is also necessary to reduce feedback of noise from the microprocessor to the IC input. Long connection lines must be shielded.

For the adjustment of the resonance frequency the capacitance of the probe and the input capacitance of the IC are to be taken into account. The alignment should be done in the final environment. The bandwidth is so low that metal parts close to the antenna influence the resonance frequency. The adjustment can be done by pushing the coil along the bar antenna.

Absolute Maximum Ratings

Parameters	Symbol	Value	Unit
Supply voltage	V_{CC}	5.5	V
Ambient temperature range	T_{amb}	-20 to +70	°C
Storage temperature range	R_{stg}	-30 to +85	°C
Junction temperature	T_j	125	°C
Electrostatic handling (MIL Standard 883 C)	$\pm V_{ESD}$	2000	V

Thermal Resistance

Parameters	Symbol	Value	Unit
Thermal resistance	R_{thJA}	70	K/W

Electrical Characteristics

V_{CCA} , $V_{CCD} = 3.0$ V, reference point pins 3, 7, 15, input signal according to JG2AS transmitter, $T_{amb} = 25^\circ\text{C}$, unless otherwise specified

Parameters	Test Conditions / Pins	Symbol	Min.	Typ.	Max.	Unit
Supply voltage range	Pins 9, 16	V_{CCA} V_{CCD}	2.4		5.5	V
Supply current $I_{CC} = I_{CCA} + I_{CCD}$	Pins 9, 16 without reception signal with reception signal > 20 μV , OFF-mode	I_{CC}			40 35 0.2	μA μA μA
Reception frequency		f_{in}		40		kHz
Minimum input voltage	$R_{gen} = 50 \Omega$ Pins 1,2 $R_{res} \leq 300 \text{ k}\Omega$, $Q_{res} > 30$	V_{in}		1.5	1.75	μA
Maximum input voltage	$R_{gen} = 50 \Omega$ Pins 1,2 $R_{res} \leq 300 \text{ k}\Omega$, $Q_{res} > 30$	V_{in}	40			mV
Input capacitances to ground	Pins 1, 2	$C_{in 1}$ $C_{in 2}$		1 1		pF
Set-up time after POWER ON		t_{pon}		2.5	5	s
TIMING CODE OUTPUT; TCO Pin 13						
Output voltage HIGH LOW	$R_{LOAD} = 13 \text{ M}\Omega$ to GND $R_{LOAD} = 2.6 \text{ M}\Omega$ to V_{CCD}	V_{OH} V_{OL}	$V_{CCD}-0.4$		0.4	V V
Output current HIGH LOW	$V_{TCO} = V_{CCD}/2$ $V_{TCO} = V_{CCD}/2$	I_{SOURCE} I_{SINK}	0.2 1		0.4 4	μA μA
Decoding characteristics input carrier reduction 200 ms input carrier reduction 500 ms 800 ms		t_{200} t_{500} t_{800}	100 450 700		250 550 900	ms ms
POWER ON/OFF CONTROL; PON pin 14						
Input voltage HIGH LOW	Generator output resistance $\leq 200 \text{ k}\Omega$		$V_{CCD}-0.4$		0.4	V V

U4222B

Test Circuit for JG2AS

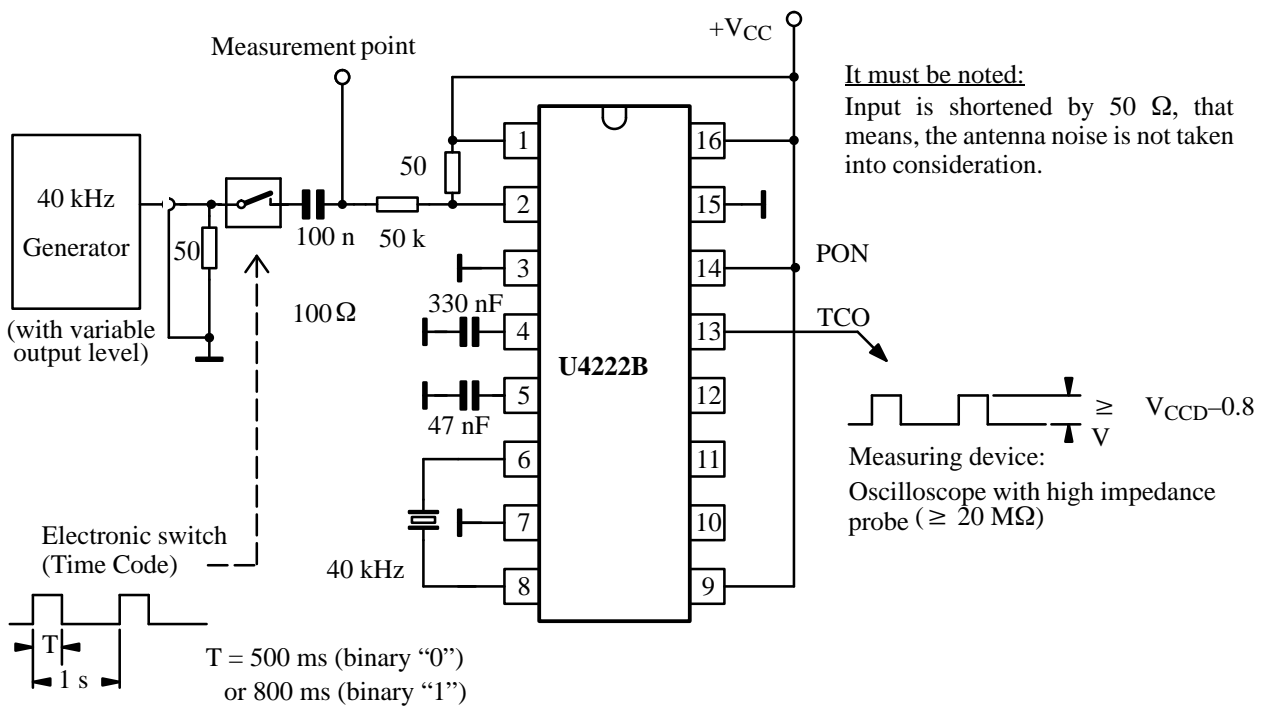

Receiver input signal calibration:

Example: $2 \mu V_{\text{eff}}$ input signal $\Rightarrow 2 \cdot 2 \sqrt{2} \cdot 10^3 = 5.65 \text{ mV}_{\text{pp}}$ at measurement point

93 7720 e

Figure 5.

Application Circuit for JG2AS 40 kHz

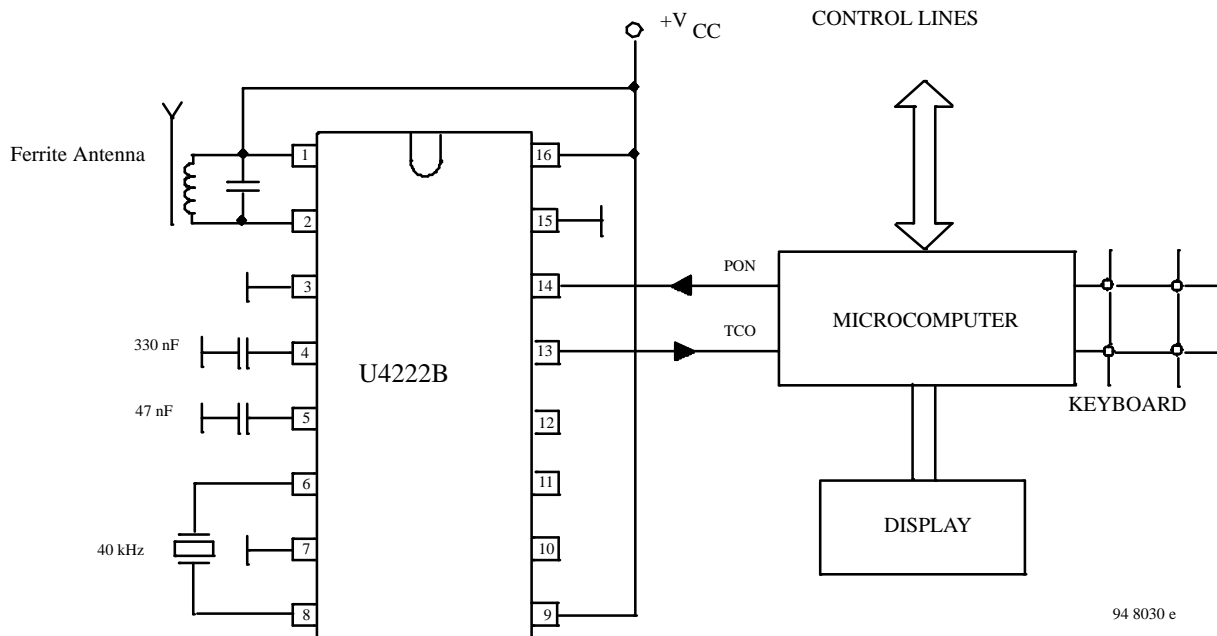

Figure 6.

Information regarding Japanese Transmitter

Station: JG2AS
 Frequency 40 kHz
 Transmitting power 10 kW

Location: Sanwa, Ibaraki
 Geographical coordinates: 36° 11' N, 139° 51' E
 Time of transmission: permanent

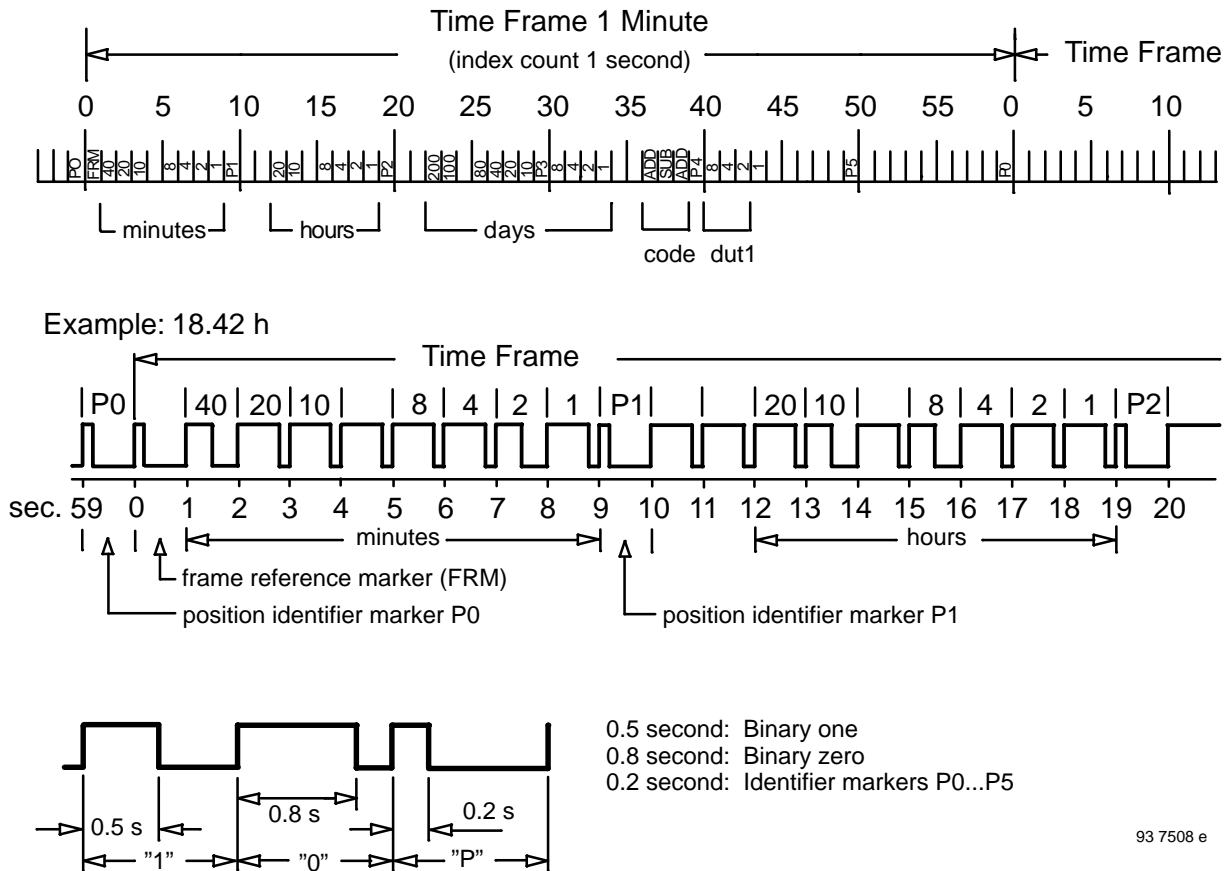

Figure 7.

Modulation

The carrier amplitude is 100% at the beginning of each second and is reduced after 500 ms (binary one) or after 800 ms (binary zero).

Time Code Format

It consists of one minute time frame. A time frame contains BCD-coded information of minutes, hours and days. In addition there are 6 position identifier markers (P0 thru P5) and one frame reference markers (FRM) with reduced carrier amplitude of 800 ms duration.

Ordering and Package Information

Extended Type Number	Package	Remarks
U4222B-CFP	SO 16 plastic	
U4222B-CFPG1	SO 16 plastic	Taping according to IEC-286-3

Dimensions in mm

Package: SO 16

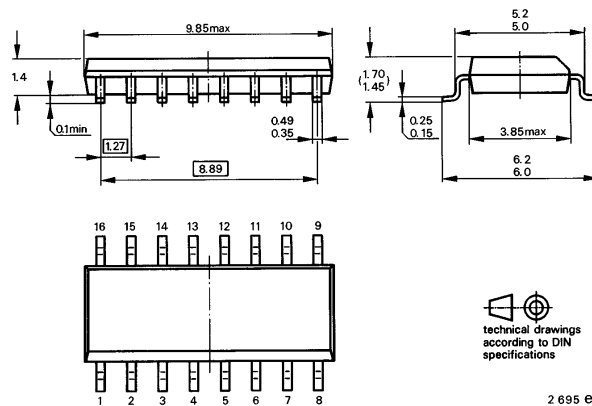

Ozone Depleting Substances Policy Statement

It is the policy of **TEMIC TELEFUNKEN microelectronic GmbH** to

1. Meet all present and future national and international statutory requirements.
2. Regularly and continuously improve the performance of our products, processes, distribution and operating systems with respect to their impact on the health and safety of our employees and the public, as well as their impact on the environment.

It is particular concern to control or eliminate releases of those substances into the atmosphere which are known as ozone depleting substances (ODSs).

The Montreal Protocol (1987) and its London Amendments (1990) intend to severely restrict the use of ODSs and forbid their use within the next ten years. Various national and international initiatives are pressing for an earlier ban on these substances.

TEMIC TELEFUNKEN microelectronic GmbH semiconductor division has been able to use its policy of continuous improvements to eliminate the use of ODSs listed in the following documents.

1. Annex A, B and list of transitional substances of the Montreal Protocol and the London Amendments respectively
2. Class I and II ozone depleting substances in the Clean Air Act Amendments of 1990 by the Environmental Protection Agency (EPA) in the USA
3. Council Decision 88/540/EEC and 91/690/EEC Annex A, B and C (transitional substances) respectively.

TEMIC can certify that our semiconductors are not manufactured with ozone depleting substances and do not contain such substances.

We reserve the right to make changes to improve technical design and may do so without further notice.

Parameters can vary in different applications. All operating parameters must be validated for each customer application by the customer. Should the buyer use TEMIC products for any unintended or unauthorized application, the buyer shall indemnify TEMIC against all claims, costs, damages, and expenses, arising out of, directly or indirectly, any claim of personal damage, injury or death associated with such unintended or unauthorized use.

TEMIC TELEFUNKEN microelectronic GmbH, P.O.B. 3535, D-74025 Heilbronn, Germany
Telephone: 49 (0)7131 67 2831, Fax number: 49 (0)7131 67 2423